

Photovoltaic (PV) Modules - LA Series

Installation Manual



WARNINGS

HAZARDOUS ELECTRICITY! CAN SHOCK, BURN, OR CAUSE DEATH! AUTHORISED, QUALIFIED PERSONNEL ONLY! DO NOT TOUCH TERMINALS! GROUND POSITIVE SIDE OF ARRAYS!

PV modules generate electricity when exposed to light. Modules may be covered with an opaque material during installation to avoid shocks or burns. Do not touch live terminals with bare hands, wear security gloves. Use insulated tools for electrical connections.

PERMIT AND INSPECTION

Contact local authorities and determine the necessary permit, installation and inspection requirements in your area.

PV MODULES

LORENTZ PV modules consist of a series of electrically interconnected crystalline silicon solar cells, which are permanently laminated within a pottant and encapsulated between a tempered glass cover plate and a back sheet. The entire laminate is secured within an anodised aluminium frame for structural strength, easy installation, and to protect the cells from the most severe environmental conditions.

APPLICATIONS

LORENTZ PV modules are ideal to power a wide range of electrical appliances in remote places far away from the electricity grid, either with or without the use of storage batteries, even under toughest climate conditions.



WARNING Not to be used for applications that connect to the utility grid. Warranty and liability void if done otherwise.

Typical applications are

- water pumping,
- water purification systems,
- remote village lighting,
- solar home systems (SHS),
- street and camp lights,
- traffic signals,
- hospitals and medical facilities,
- microwave/radio repeater stations,
- battery charging,
- telecommunication systems,
- etc.

SITE SELECTION, TILT ANGLE

In most applications, the location of LORENTZ PV modules should be chosen to provide maximum irradiation throughout the year. In the Northern hemisphere, the modules should face south, and in the Southern hemisphere, the modules should face north. Modules facing 30° away from true South (or North) will lose approximately 10-15 % of their power output. If the module faces 60° away from true South (or North), the power loss will be 20-30 %.

The module tilt angle is measured between the solar modules and the ground (Figure 1). For installations where the solar modules are attached to a permanent structure, the solar modules should be tilted for optimum winter performance. If the system power production is adequate in the winter, it will be satisfactory during the rest of the year. Refer to Table 1 for the recommended module tilt angle at your site.

Avoid trees, buildings or obstructions which could cast shadows on the solar modules especially during the winter months when the arc of the sun is lowest over the horizon.

Table 1: Recommended tilt angles for fixed systems based on Winter Performance

site latitude	fixed tilt angle
0° to 15°	15°
15° to 25°	same as latitude
25° to 30°	latitude + 5°
30° to 35°	latitude +10°
35° to 40°	latitude +15°
above 40°	latitude +20°

INSTALLATION

Installation by qualified personnel only. Personnel must know the appropriate safety procedures.

- Sunlight shall not be concentrated on the module.
- LORENTZ PV modules are quite rugged; nonetheless the glass can be broken (and the module will no longer work properly) if it is dropped or hit by tools or other objects, or when the modules are stepped upon.
- Module support structures that are to be used to support LORENTZ PV modules should be wind rated according to local conditions and approved for use by the appropriate local and civil codes prior to installation.

Fixation

The frame of each module has four 6.6 mm diameter (0.26 ") mounting holes to fix the modules to the supporting structure. The four holes close to the corners of the module are most often used for attachment. Refer to drawing in the product information sheet for the position of these holes.

The stainless steel hardware (e.g. AISI 304) used for securing the module frame should be secured with an applied torque of about 8 Nm (6 foot-pounds).



In order to protect the electric connections from dampness and rain, the PV module must be set up in such a way that the notches of the junction box are orientated downwards.



Clearance between the module frame and the mounting surface may be required to prevent the junction box from touching the surface, and to allow the circulation of cooling air around the back of the module. If the modules are to be installed on the roof or wall of a building, the standoff method or the rack method is recommended.



The module frame is made of anodised aluminium; therefore corrosion can occur if the module gets in contact with another type of metal in a salt water environment (electrolysis corrosion). To avoid this, PVC or stainless steel washers can be placed between the solar module frame and support structure.

WIRING

All of the LORENTZ PV modules utilise a junction box. This junction box, located on the back side of the module, is weatherproof and is designed for standard wiring or conduit connections (for all modules with less than 40Wp). For LA modules of 75 Wp and more cables are included.



Proper connection of the cables in the junction box must be checked especially for modules with pre-assembled cables as vibrations during transport might loosen the wiring. Connectors must be used with same type only to guarantee safe connection.

LORENTZ advises that all wiring and electrical connections comply with National Electrical Codes. A cable clamp with a minimum rating of IP65 must be used to maintain the weatherproof integrity of the junction box. Bypass diodes are preinstalled at factory.

To wire LORENTZ PV modules:

- Determine the nominal system array voltage of your system. Each panel is equivalent to a 12VDC nominal block for 12S modules and 24VDC nominal block for 24S modules. Standard array voltages 12, 24, 48 and 96V are shown as examples in Figure 3.
- The wire used to interconnect the solar modules may be single or two conductors, from 2 mm² (AWG 14) up to 6 mm (AWG 10) gauge stranded copper wire, in a sunlight-resistant jacket UF cable that will not degrade when exposed to the direct sunlight. The maximum and minimum outer diameters of the cable that may be used with the cable connector are 8 mm and 6 mm respectively.
- Route wires through the PG plugs and clamps refer to installation example.
- Gently hand-tighten the terminal screws with cross tip (Phillips head) screwdriver. Do not over tighten to avoid damages to the terminal.
- The output wiring from the final module is generally run to a separate array junction box. In commercial system, this wiring from the array box to the next component (i.e. fuse box or charge regulator etc.) is generally run in conduit. The maximum electrical rating of an acceptable series fuse is 6 to 12A.
- After checking that module wiring is correct, close all the junction boxes and ensure a waterproof seal.

GROUNDING

LORENTZ PV modules must only be used in configurations with galvanic insulated inverters, that are not connected to the grid (stand alone inverters), with the positive (+) polarity of the PV array connected to ground protected by a fuse. Failure to comply with this requirement will reduce the performance of the system and void the Limited Power Warranty.

Attach all module frames to an earth ground. Attach a separate ground wire to one of the holes marked "ground" on the module frame with a screw and bonding or external tooth washer. This is to ensure positive electrical contact with the frame. The racks must also be grounded unless they are mechanically connected by nuts and bolts to the grounded modules. The array frame shall be grounded in accordance with NEC Art. 250.

Positive Grounding

LORENTZ PV modules – LA series – use all-back contact solar cells for high efficiency. This technology leads to possibly suffering from a temporary decrease in performance if installed according to common methods without grounding or with negative grounding. This effect is due to a surface polarization effect caused by a small amount of leakage current from the module. While all modules experience some amount of leakage current, the surface polarization effect seems to be unique to thin-film and back-contact solar cells.

If the frame of the module is on a low potential compared to the cells voltage, the leakage current flows from the cells through the glass to the frame. This causes a negative effect in the cells which decreases the performance of the module.

This surface polarization effect is normally reversible by positive grounding. It usually does not cause any damage to the module. The performance of a system that has been installed according to common methods (without grounding or with negative grounding) and is suffering from decreased performance can normally be restored by wiring it as a positive-grounded system.

If an off-grid AC stand alone inverter is used and the system is positive-grounded, an isolated type must be applied. Most standards forbid using a non-isolated (trafoless) stand alone inverter in a system grounded on the DC side, as it can be dangerous. There must be a real electrical separation between DC and AC.

To avoid a negative charge on the frame and thus on the surface of the modules, the system has to be grounded on the most positive voltage in the system, which is the positive pole of a single module or the whole string. In every case, ground has to be connected to the frame of the modules.

If real grounding is not possible, at least the frame has to be connected to the most positive in the system. Basically, ground has to be connected only at one single point to the most positive voltage of the system. See figure 4.

Make sure to follow the local standards and codes.

BLOCKING DIODES

Blocking diodes are typically placed between the battery and the PV module output to prevent battery discharge at night. LORENTZ PV modules are made of monocrystalline cells with high electrical "back flow" resistance to night-time battery discharging. As a result, LORENTZ PV modules do not contain a blocking diode when shipped from the factory. Most PV charge regulators do have night-time disconnect feature, however.

BYPASS DIODES

Partial shading of an individual module in a 12V or higher source circuit string (i.e. two or more modules connected in series) can cause a reverse voltage across the shaded module. Current is then forced through the shaded area by the other modules. When a bypass diode is wired in parallel with the series string, the forced current will flow through the diode and bypass the shaded module, thereby minimizing module heating and array current losses.

Diodes that are used as bypass diodes must:

- have a Rated Average Forward Current [IF(AV)] above maximum system current at highest module operating temperature.
- have a Rated Repetitive Peak Reverse Voltage [VRRM] above maximum system voltage at lowest module operating temperature.

BATTERY

When using the solar modules for charging batteries, the battery must be installed in such way as ensures the performance of the system and the safety of its users. Follow the battery manufacturer's guidelines for installation, operation and maintenance recommendations. The battery (or battery bank) should be kept from passing-by people and animal traffic, protected from sunlight, rain, snow, debris, and its location be well ventilated. Most batteries generate hydrogen gas when charging, which can be explosive; in this case provide sufficient ventilation and do not light matches or create sparks near the battery bank. For outdoor installation, the battery should be placed in an insulated and ventilated battery case that is specifically designed for the purpose.

MAINTENANCE

Inspect all PV modules annually for safe electrical connections, sound mechanical connection and freedom from corrosion.

Normally the rainfall is sufficient to keep the module glass surface clean. If dirt build-up becomes excessive, clean the glass surface only with a soft cloth using mild detergent and water. Remove fingerprints with standard glass cleaner. Do not use harsh cleaning materials, such as scrapers, steel wool, blades or other sharp instruments to clean the surface; this will void the warranty.



Use caution when cleaning the back surface of the module to avoid penetrating the PVF sheet.

Modules that are mounted flat (0° tilt angle) should be cleaned more often, as they will not "self-clean" as effectively as modules mounted at a 15° tilt or greater.

Once a year, check the tightness of terminal screws and the general condition of the wiring. Make sure that mounting hardware is tight. Loose connections will result in a damaged module or array.

NOTES

- The electrical characteristics are indicated values of Pmax under standard test conditions (irradiance of 1,000W/m², AM 1.5 spectrum, and cell temperature of 25° C).
- Under certain conditions, a photovoltaic module is likely to produce more current and/or voltage than reported at standard test conditions. Accordingly, the values of Isc and Voc marked on this module should be multiplied by a factor of 1.25 when determining component voltage ratings, conductor ampacities, fuse sizes, and sizes of regulators which are connected to the PV output.

Figure 1
Tilt Angle

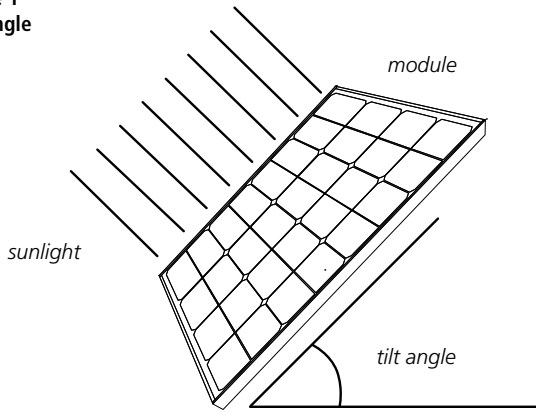

Figure 2
Fixation with screws

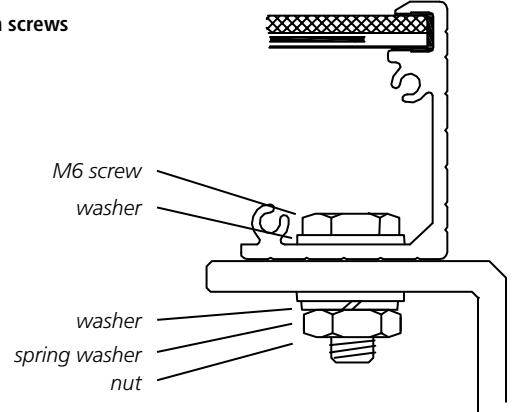

Figure 3
Standard Wiring Examples

Figure 3a
12V ($V_{mp} \sim 17V$) parallel for 12S modules
24V ($V_{mp} \sim 34V$) parallel for 24S modules

Figure 3b
24V ($V_{mp} \sim 34V$) series for 12S modules
48V ($V_{mp} \sim 68V$) series for 24S modules

Figure 3c
48V ($V_{mp} \sim 68V$) series for 12S modules
96V ($V_{mp} \sim 136V$) series for 24S modules

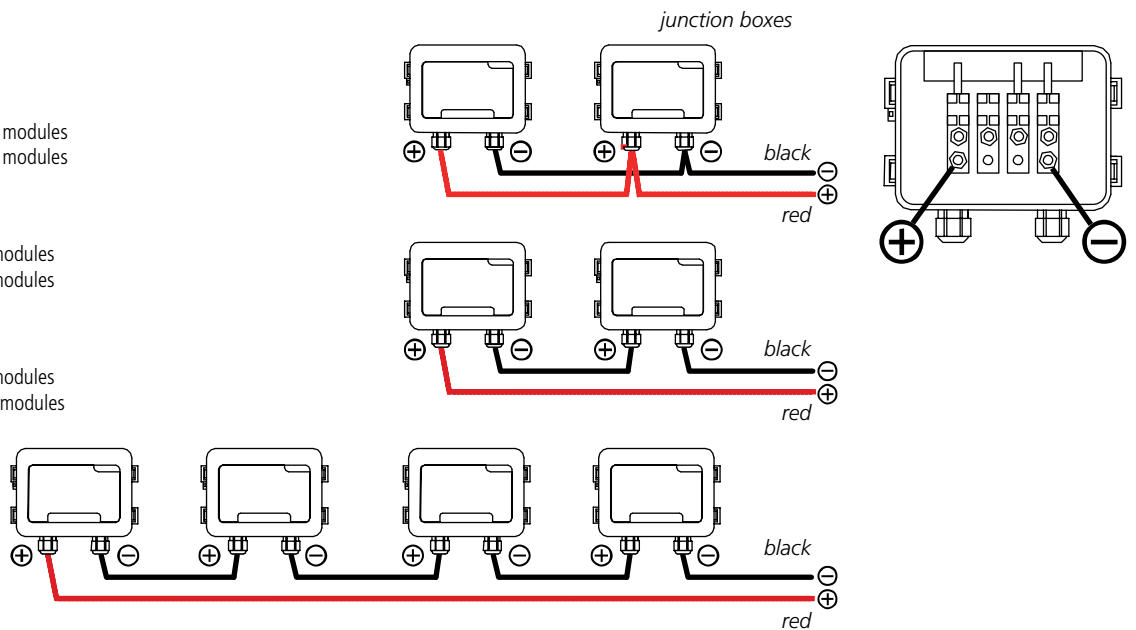

Figure 4
Positive Grounding

Figure 4a:
Connecting a single module

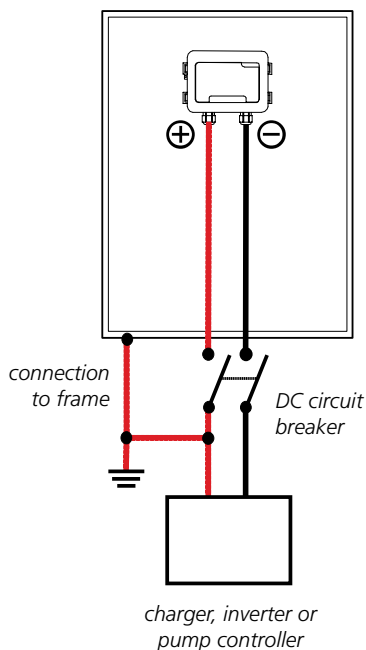

Figure 4b:
Connecting two or more modules in series

